



University Learning Fair [®] _{TM}

The fair for makers and providers of analogue and digital teaching materials as well as related activities for further education!

INVITATION

2019 5.-6.
MARCH

Organisers:



Concept developers and operators



Business partners

INVITATION & WELCOME TO UNIVERSITY LEARNING FAIR

- For those of you who wish to showcase your products and services within the field of teaching materials and related activities to decision-makers, teachers and students for further education!

On 5 and 6 March, we will open the doors for the second time to University Learning Fair, the fair where it will be possible for you and your company/organisation to showcase your products and services to educational institutions.

At the fair, you will be able to demonstrate your classical as well as your latest innovations within teaching materials to a wide audience of decision-makers, teachers and students for further education in Denmark.

In addition to the creation of an active marketplace for existing products and services, it is also our vision to create an active forum where suppliers, decision-makers and users can meet and exchange knowledge, experience and wishes for the activities of the future.

Such interaction between companies and users will, at the same time, provide an opportunity for a basic exchange of ideas which may influence the future development of teaching materials and technologies.

As a maker and provider of teaching materials, the fair will give you a direct feel for the market via your dialogue with the visitors, all the way through to the end-users.

University Learning Fair is geographically placed in the centre of Aarhus University where its main building provides a beautiful setting for the fair.

We look forward to welcoming you to a professional fair experience which can help you showcase your products and services!

Yours faithfully,



Tom A. Poulsen



Jens Viltoft



INDEX

Sessions	3
The 2019 fair	4
Practical and technical information	5
The stands	6
Overview of the stands	7-8
Registration	9
Terms and conditions	10
The 2018 fair	11

SESSIONS AT THE UNIVERSITY LEARNING FAIR

At the fair, there will be a number of sessions where we have invited those who each in their own area have an idea of the future development within this field.

As an exhibitor, it will also be possible for you to make a 30-minute presentation or demonstration of what your products and services can do and what the future holds.



It will, for instance, be possible to meet Preben Mejer, a source of great knowledge and motivator. Preben Mejer has been named one of Denmark's ten

most influential people within IT by Computerworld and the most innovative Danish IT-personality by Børsens Nyhedsmagasin.

Preben Mejer was unfortunately not able to attend the University Learning Fair in 2018 but given his huge interest in the fair, it was obvious that he should attend in 2019.

The sessions programme will be filled up during 2018 and registration takes place on a first come, first served basis and if you wish to book a time for you and your organisation or company, you can include this on your registration or forward any times you would like to us using the below-mentioned contact information.

Your request shall contain the following information:

- Own name of company/organisation
- Time requested for presentation
- Possible name of presenter
- Short description of the contents of the presentation or demonstration, possible title
- Max. 100 characters

Generally:

The room allocated for the presentation will be equipped with light, sound, projector, Wi-Fi as well as 230V power.

The price of the room with the above-mentioned equipment is included in the price of a stall at the fair.

If other equipment or material is required, please contact us.

Presentation and demonstrations are announced in the marketing of the fair.

Presentation times Tuesday, 5 March

10.00-10.30	14.00-14.30
10.30-11.00	14.30-15.00
11.00-11.30	15.00-15.30
11.30-12.00	15.30-16.00
12.00-12.30	16.00-16.30
12.30-13.00	16.30-17.00
13.00-13.30	17.00-17.30
13.30-14.00	17.30-18.00

DAY 1

Presentation times Wednesday, 6 March

10.00-10.30	12.30-13.00
10.30-11.00	13.00-13.30
11.00-11.30	13.30-14.00
11.30-12.00	14.00-14.30
12.00-12.30	14.30-15.00

DAY 2

CONTACT

Sales & Registration
Jane Trendholm
Tel. +45 61 66 85 17
E-mail: adm@apuss.dk

THE 2019 FAIR

Aarhus University's great hall provides the perfect physical setting for the University Learning Fair 2019, geographically placed in the centre of Aarhus with good transport links and easy access for all visitors.



The choice of this location has been made on the basis of possible requests for workshops, presentations, special demos or personal meetings which this fair enables.



Our staff is at your disposal before, during and after the fair. Included in the price of your stand at the fair are meals for your employees who are running the stands.



ALL VISITORS ARE ADMITTED FOR FREE!

Additional technical information material for your advertising needs will be forwarded in connection with your registration. You can also find it at: www.apuniversitysolutions.dk → Info for advertisers and exhibitors → University Learning Fair → Practical Info.

MARKETING

Extensive advertising aimed at the fair's visitors is also included in the price of the stand.

Decision-makers and teachers will be invited directly, in writing, as of the start of November. As of January, promotional activities in connection with the fair will be intensified, targeting all visitors.

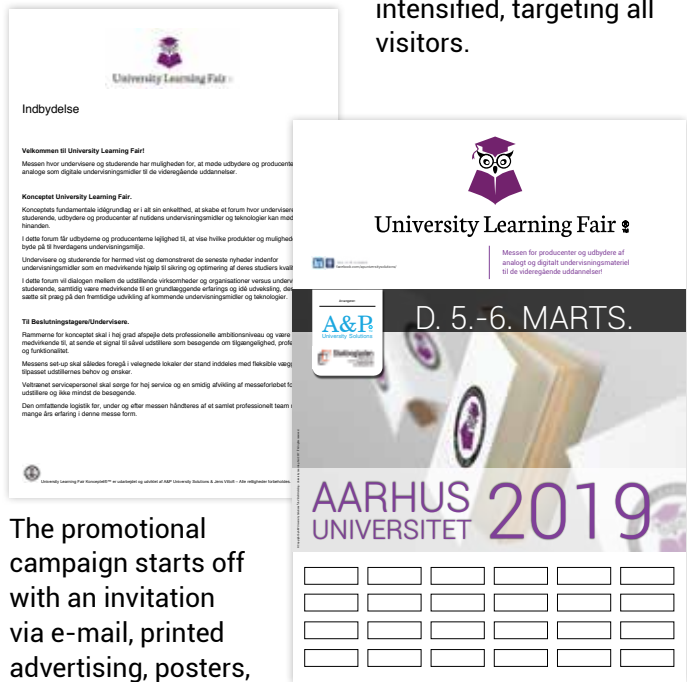

The promotional campaign starts off with an invitation via e-mail, printed advertising, posters, competitions as well as merchandise.

Added to this will be digital advertising which in the weeks leading up to the fair will be supplemented by field promotion at the educational institutions.

As a registered exhibitor, you will also receive finished material for use on your own website or other electronic platforms enabling you to promote your participation in the fair to your existing customers and users.



PRACTICAL AND TECHNICAL INFORMATION

Opening hours

The fair will be open on 5 & 6 March.
 Tuesday, 5 March from 10 am–6 pm.
 Wednesday, 6 March from 10 am–4 pm.

Registration

Registration can be completed via the enclosed registration form which can be scanned as a PDF and e-mailed to: adm@apuss.dk or forwarded as mail to:

A&P University Solutions
 Haldrupvej 42 – Søvind
 8700 Horsens

Electronic registration on our website www.apuniversitysolutions.dk under the menu item "messer" – University Learning Fair.

Prices

Small stand with a floor area of 3.75 m ²	DKK 9.900,00
Large stand with a floor area of 7.5 m ²	DKK 14.500,00
Special stand with a floor area of min. 10 m ²	1.800 per m ²

The above prices are inclusive of full advertising and meals for the exhibitor's staff at the fair.

The above stands are mounted, complete with a neutral white back wall and two side walls mounted with 205 g fire-resistant banners (see outline on page 5).

All stands are equipped with three 230 V outlets as well as wireless Internet.

Optional Extras

Print of an individually designed wall for the fair based on a forwarded PDF	DKK 2.495,00 <i>(price includes renting of stand material).</i>
Print of an individually designed table for the fair based on a forwarded PDF	DKK 1.495,00 <i>(price includes renting of table material).</i>
Spots mounted on the back wall and side walls	DKK 395,00 <i>(price includes a total of four spots).</i>

Mounting & Demounting

Design and decoration of stands or mounting of own stands may take place on Monday, 4 March between the hours of 8 am and 6 pm.

Demounting of stands may take place on Wednesday, 6 March between the hours of 4 pm and 10 pm.

Forwarding of equipment and materials may take place on Monday, 4 March between the hours of 8 am and 6 pm.

Please contact us in connection with any deviations from these timetables..

Please contact us for additional information or find more information at www.apuniversitysolutions.dk

CONTACT

Sales & Registration
 Jane Trendholm
 Tel. +45 61 66 85 17
 E-mail: adm@apuss.dk

Head of sales
 Tom A. Poulsen
 Tel. +45 61 28 85 17
 E-mail: tp@apuss.dk

THE STANDS

As Standard

When you purchase a stand, it is pursuant to our standards equipped with our standard walls and a neutral white background fabric.

It is at the same time possible to use a cafe table or a smaller rectangular standard table. This is, of course, also included in the price of your stand.

Own Material

If you bring your own stand to the fair, this can be set up within the walls or we can take down the walls to create more space for your own equipment. Please contact us.

Print Your Own Stand

If you do not bring your own stand, but you would like to profile your company's/organisation's messages on a grand scale, you have the option of having your own stand at the fair printed pursuant to your own individual design.

Send us a PDF with your own print/design and the stand will be ready for you when you arrive at the fair.

If you would also like your own print on a professional table at the fair, this can be done in the same way.

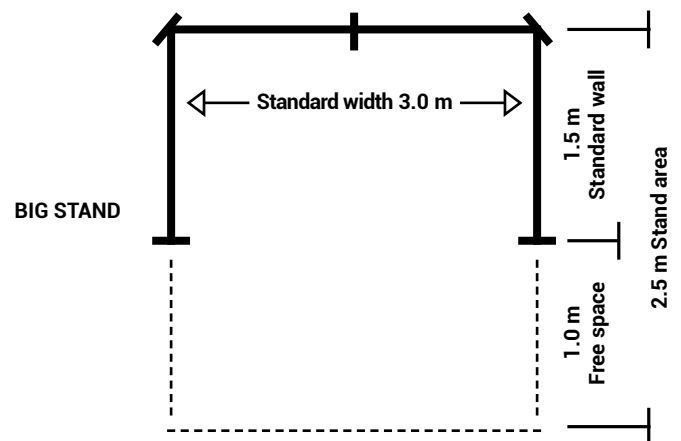
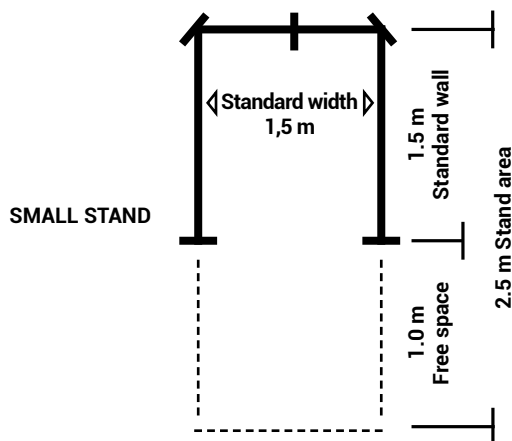

Standard stand and tables with your own print



On the previous page, you can see the prices for printing your own wall and table at the fair, to make the process easier we have produced templates in various file formats enabling you to design your own stand quickly and easily. If you need professional help with your design or set-up, our graphical designers are at your disposal.

For additional information and offer please contact:

Head of sales, Tom A. Poulsen

Tel. +45 61 28 85 17

E-mail: tp@apuss.dk

ALL VISITORS ARE ADMITTED FOR FREE!

Additional technical information material for your advertising needs will be forwarded in connection with your registration. You can also find it at: www.apuniversitysolutions.dk → Info for advertisers and exhibitors → University Learning Fair → Practical Info.

OVERVIEW OF THE STANDS - THE GREAT HALL (AULA)

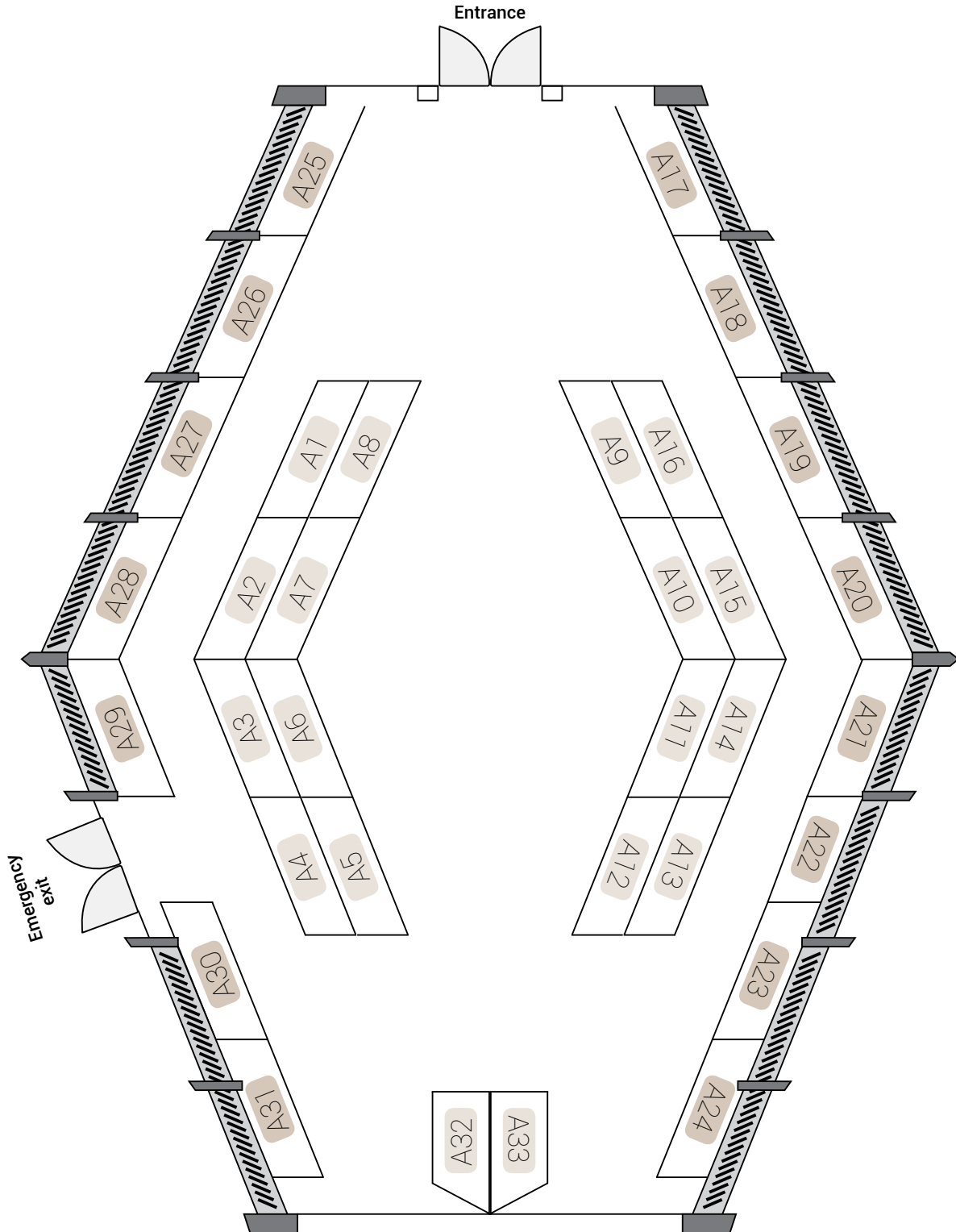

Depending on the wishes and needs of the exhibitors, we reserve the right to make changes to the plan for the stands and the rooms. Each of the numbers represents a large stand. A small stand is a large stand divided into two.

OVERVIEW OF THE STANDS - THE LOBBY (FOYER)

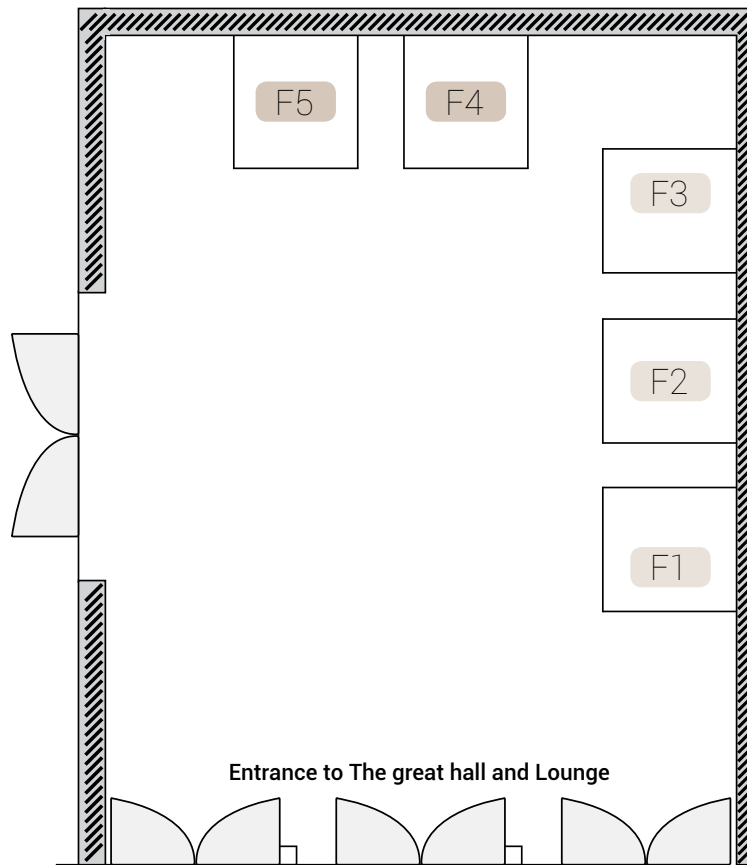

OVERVIEW OF THE STANDS - THE LOUNGE (VANDREHALLEN)

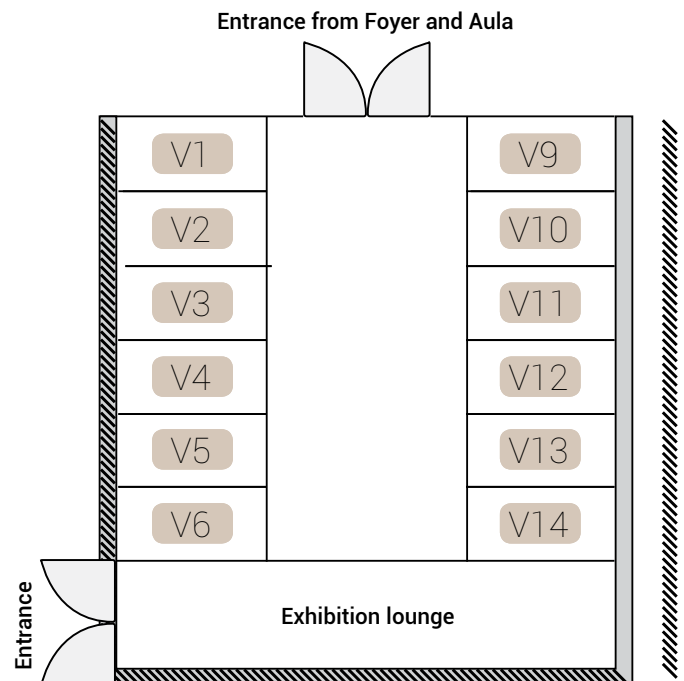

Depending on the wishes and needs of the exhibitors, we reserve the right to make changes to the plan for the stands and the rooms. Each of the numbers represents a large stand. A small stand is a large stand divided into two.

REGISTRATION FOR UNIVERSITY LEARNING FAIR 2019 – AARHUS

The undersigned hereby registers for University Learning Fair 5 and 6 March 2019 at Aarhus University
Stand (mark)

Small stand with a floor area of 3,75 m²
DKK 9.500,00.

Large stand with a floor area of 7,5 m²
DKK 14.500,00.

Special stand with a floor area of min. 10 m²
DKK 1.800,00. pr. m²

A total of _____ m² is requested

The above prices are inclusive of full advertising and meals for the exhibitor's staff at the fair.

Presentation/demonstration requested
Title _____

Tuesday, 5 March from _____ to _____
Wednesday, 6 March from _____ to _____
Performed by _____

Optional extras (mark)

Print of an individually designed wall for the fair based on a forwarded PDF
DKK 2.495,00. (Price includes renting of stand material).

Print of an individually designed table for the fair based on a forwarded PDF
DKK 1.495,00. (Price includes renting of table material).

Spots mounted on the back wall and sides
DKK 395,00. (Price includes a total of four spots).

Stand and participants (mark) *Registration can also take place electronically at www.apuniversitysolutions.dk*

Requested stand no.: _____ Number of exhibitors at the stand: _____

Own complete stand to be set up independently.
Other special requests: _____

Company/organisation: _____ Contact in charge: _____

Direct tel. no.: _____ E-mail: _____

Person in charge at the stand:: _____ Direct tel. no.: _____ E-mail: _____

Company address: _____ Postal code: _____ City: _____

Company/organisation tel. no.: _____ EAN no. (if relevant): _____

The undersigned is aware of University Learning Fair's and A&P University Solution's terms and conditions which can be found on the back of this registration form. All the above-mentioned prices are ex. VAT.

Registered with University Learning Fair A&P University Solutions on _____ / _____ 2018. By: _____

IF YOU REGISTER AFTER 15. JANUARY, PRINTED ADS WILL LAPSE.

TERMS AND CONDITIONS

f/ University Learning Fair A&P University Solutions

Advertising material:

The prices apply to all advertising material if received as finished PDF files with a 300 dpi solution - CMYK.

Any processing work such as retouch, adaptation or other changes to the original material which is necessary in order to be able to reproduce the material, will be charged on the basis of the time spent and pursuant to the valid hourly rate, cf. separate price list.

University Learning Fair A&P University Solutions may at any time refuse the acceptance/publication of material if this is found to be of unacceptable quality or is considered to be in violation of the bona fide and established practices of the trade.

Deposit & Payment terms:

Upon receipt of a signed registration form or electronic registration via website, University Learning Fair A&P University Solutions forwards an invoice for the amount of DKK 3,500 to cover the deposit. The amount is deducted from the final invoice.

On the dates stated in the registration form, University Learning Fair will be held at the location, also described on the form and 14 days at the latest before this final invoice will be forwarded.

Payment terms: Net 14 days from the invoicing date.

All the list prices are given in DKK, ex. VAT.

In case of a late payment, 2% interest is added for each month.

Cancellation:

Cancellation shall be sent in writing to University Learning Fair A&P University Solutions 45 days at the latest before the date of the first day available for mounting the stands for the University Learning Fair.

Written cancellation in due time does not entail any refund of the paid deposit which without any form of quid pro quo falls to University Learning Fair A&P University Solutions for the covering of costs already paid.

If written cancellation takes place in due time but after a time where advertising has been ordered and the advertising material has been forwarded, University Learning Fair A&P University Solutions reserves the right to forward an invoice for the collection of the total advertising price in addition to the deposit already paid which primarily covers the costs associated with the stand itself.

Despite the kept deposit and payment of the price of the advertising, cf. the invoice forwarded by University Learning Fair A&P University Solutions, University Learning Fair

A&P University Solutions reserves the right not to publish the advertising in question from a non-participating exhibitor who has sent a written cancellation in due time.

Stands and advertisements as well as publications and inserts where special placements have been ordered cannot be cancelled without prior written agreement with University Learning Fair A&P University Solutions.

University Learning Fair A&P University Solutions reserves the right, by giving 14 days' notice before the holding of University Learning Fair, to cancel the fair without any sort of further documentation or compensation to the exhibitors at University Learning Fairs, with the exception of the deposit paid by the exhibitors.

Complaint:

University Learning Fair A&P University Solutions does not assume any responsibility for errors in any material which has been published in accordance with information from the orderer and the undersigned registration/advertising confirmation.

This also applies to material received from third parties, material which does not meet the stated technical requirements and specifications from University Learning Fair A&P University Solutions or if the stated deadline for registration form/media guide has been exceeded.

For printing errors, wrong sizes, times, etc., for which the advertiser or University Learning Fair A&P University Solutions is not responsible, a reduction in price will be offered at University Learning Fair A&P University Solutions' own discretion, which at most may amount to the price of the stand/advertisement for participating/publishing in University Learning Fair A&P University Solutions.

Complaints in regards to printing errors, colour errors and the like shall be sent to University Learning Fair A&P University Solutions in writing 5 weekdays at the latest after publication.

Claims for compensation cannot be made against University Learning Fair A&P University Solutions for delays, incorrect or a lack of a stand and/or insertion of ordered advertisements and/or inserts or for any effects of such errors.

If nothing else is stipulated in connection with the above, A&P University Solutions, Albæk & Poulsen's general terms and conditions shall apply. You can find these at www.apuniversitysolutions.dk under "Om os - Generelle Betingelser".

University Learning Fair A&P University Solutions.
Aarhus 1/9/2017.

THE 2018 FAIR

In February 2018, University Learning Fair got off to its tentative beginnings and has since then gotten a lot of attention due to its concept, professional contents and the way in which it was held.

This positive increase in attention has led to educational

institutions wanting to include it in their planning already shortly after the summer holiday and that means we have had to extend a number of deadlines for the 2019 fair.



At the 2018 University Learning Fair, the following participated, among others:





University Learning Fair [®] _{TM}

The fair for makers and providers of analogue and digital teaching materials as well as related activities for further education!

WE COOPERATE, AMONGST OTHERS, WITH:

- Arkitektskolen
- Journalisthøjskolen
- Det Jyske Musikkonservatorium
- Erhvervsakademi Aarhus
- Ingeniørhøjskolen i Aarhus
- Via University College
- Aarhus Maskinmesterskole
- Aarhus Universitet

Are you also planning a professional event for your organisation? Contact us and hear all about the many options we offer.

Visit us at
www.apuniversitiesolutions.dk